

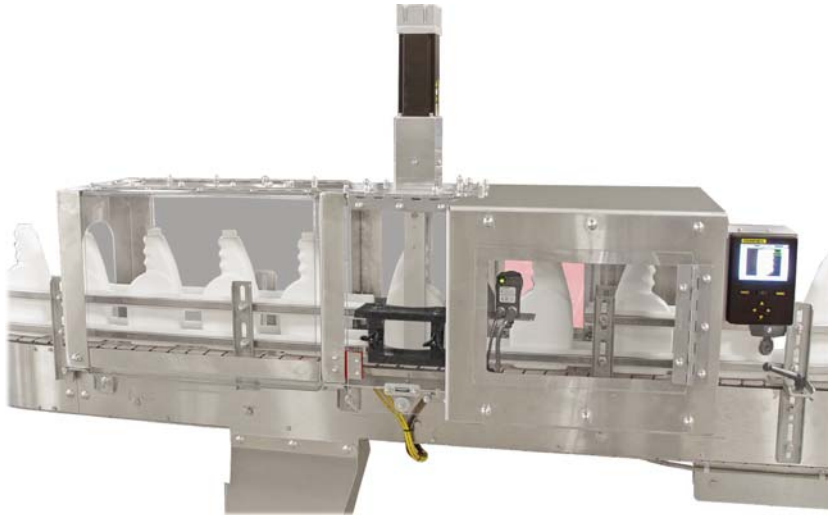

Bottle Orienter

NECO-ORIENTER

Orients non-round bottles into one direction.



Standalone
NECO-ORIENTER



NECO-ORIENTER
Integrated with NECOSORT-54
Plastic Bottle Unscrambler

Nalbach Engineering's Inline "0/180" degree orienter quickly, simply and inexpensively orients bottles into a common direction.

The NECO-ORIENTER Inline "0/180" degree bottle orienter is a servo driven system designed to turn non-round bottles into a common direction. Bottles are accepted from a single lane source and, based upon a Vision sensor's output allowed to pass if they are properly oriented, or spun 180 degrees if they are not properly oriented.

Benefits

- Fast. Runs speeds to 250 bpm.
- Simple. The servo motor is the only moving component in the system.
- Inexpensive. Simplicity means lower cost, lower maintenance and higher reliability.
- Easy Access. Hinged top provides easy access to all components and conveyor area.
- Servo Driven. Direct coupled servo drive design reduces part count while providing speed and accuracy.
- Vision system detects the smallest details for fast, easy, and accurate system setup.
- LEXAN enclosure provides complete visibility of the system's operation.
- Small and compact for easy integration. Easily fits into existing layouts without requiring a large section of dedicated conveyor.
- Fast changeovers. Easy change "turning forks" quickly and accurately change from one bottle format to another.

Video:

Scan the QR Code to watch the NECO-ORIENTER in action.



About Nalbach Engineering Company

Founded in 1945, our Company has earned its dominant reputation for quality and performance in the design and manufacture of a complete line of plastic bottle unscramblers and powder filling equipment. In addition, we offer aerosol fillers, turnkey packaging lines, and system integration services. A member of PMMI since 1958, Nalbach Engineering has developed equipment for a widely diverse client roster of Blue Chip companies and has installed systems in 45 countries around the globe.



NECO-ORIENTER How it Works

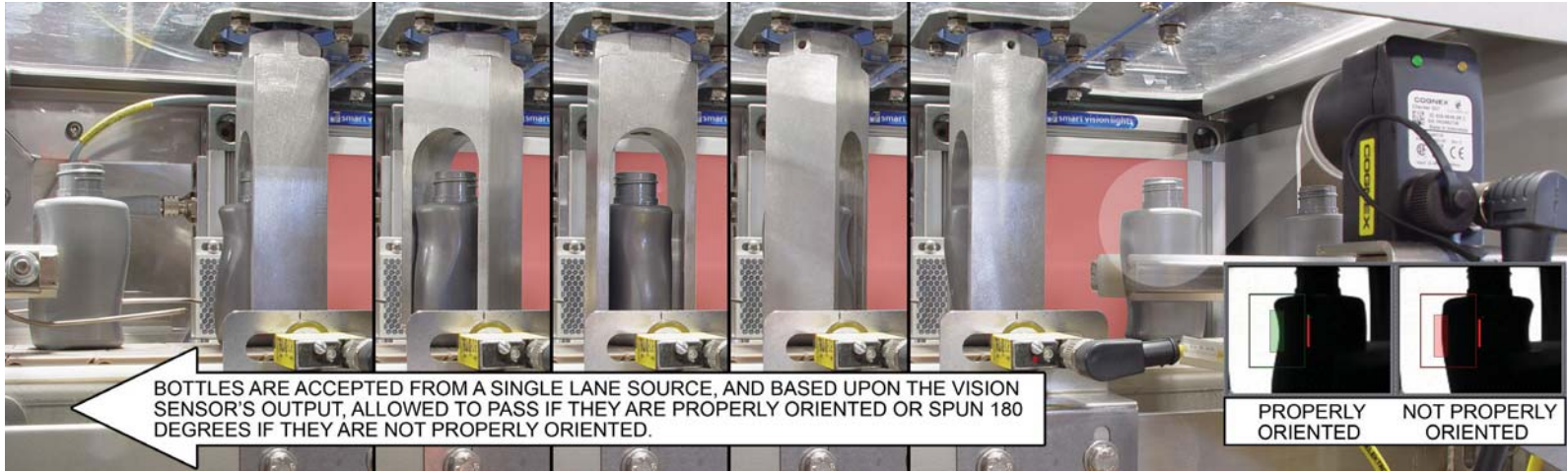

DIMENSIONS MAY CHANGE DEPENDING ON RANGE OF BOTTLE FORMATS TO BE RUN.

Standalone
NECO-ORIENTER

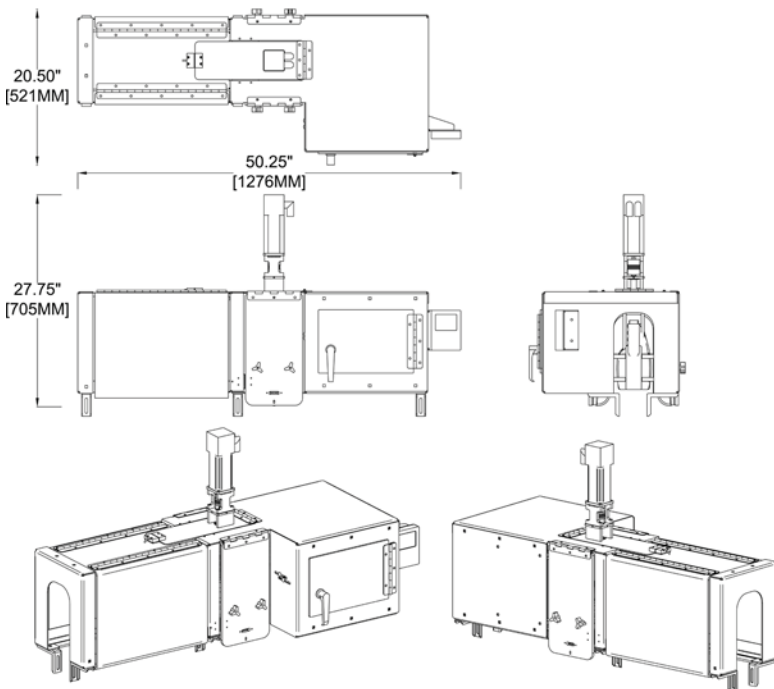

NECO-ORIENTER
Integrated with
Bottle Unscrambler

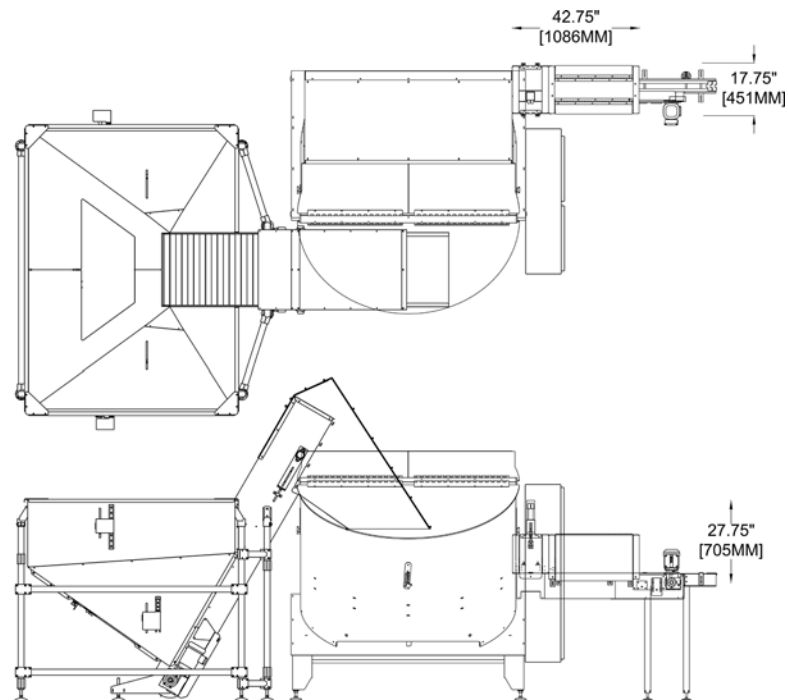

Dimensions Subject to Change Without Notice

